

# GRIND CUSTOMS FX

[WWW.GRINDCUSTOMSFX.COM](http://WWW.GRINDCUSTOMSFX.COM)

## CLEGGSTER PSU

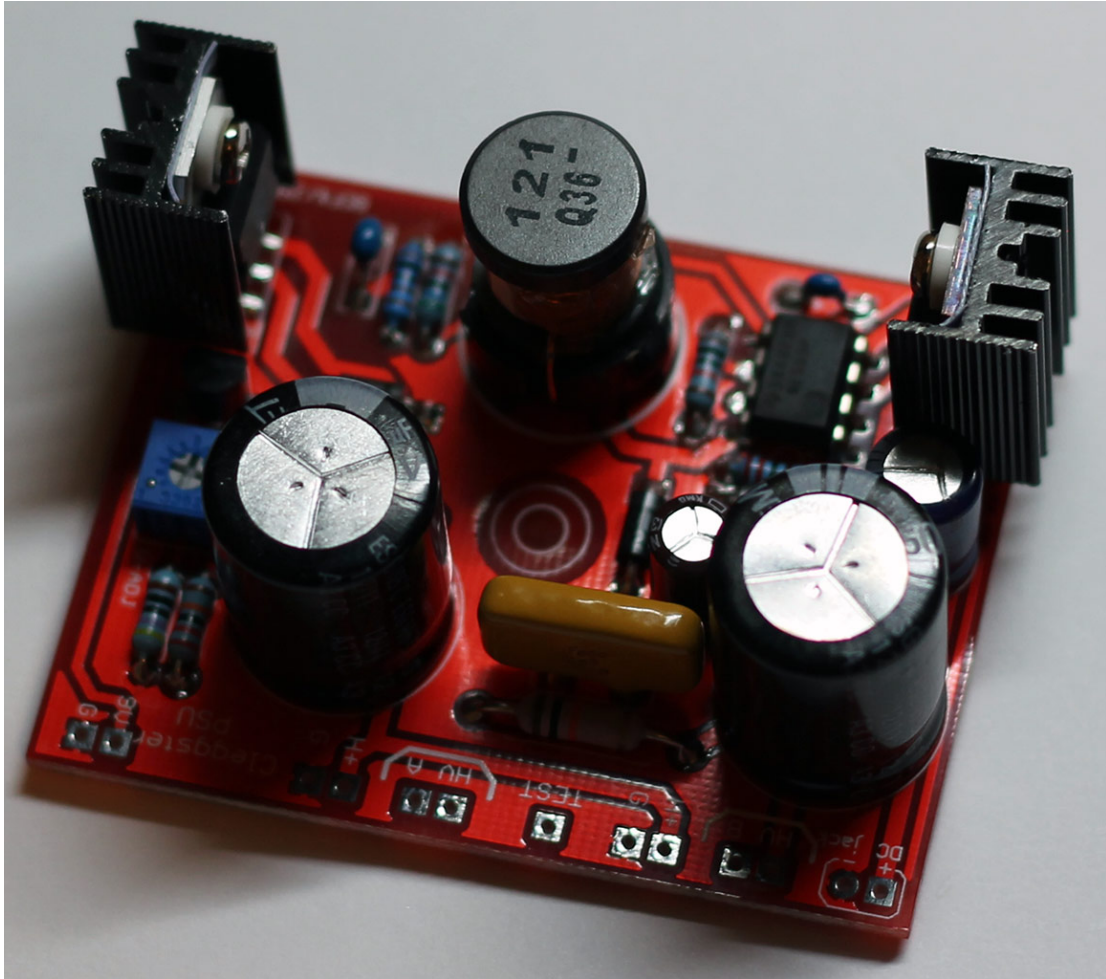

### GROUP HUG

This project is another unholy alliance of four people in three different countries: PCB elf Jason (Jubal81), Rej, Cleggy and myself (Juansolo). It's like a intercontinental DIY love-in. Or something.

### OVERVIEW

This project is based on a Nixie PSU design that has been tailored to be more suitable for high voltage guitar effects pedals utilizing valves ('toobs' for people in the US).

When I say high voltage, I mean it. This project is not to be taken lightly. You are dealing with proper voltages here that can give you a hell of a crack at the very least, and potentially much worse. In the interests of safety, we employed a French Canadian to test this (twice) and he reported back that it bloody hurt. So check and double check before you power it up.

# GRIND CUSTOMS FX

[WWW.GRINDCUSTOMSFX.COM](http://WWW.GRINDCUSTOMSFX.COM)

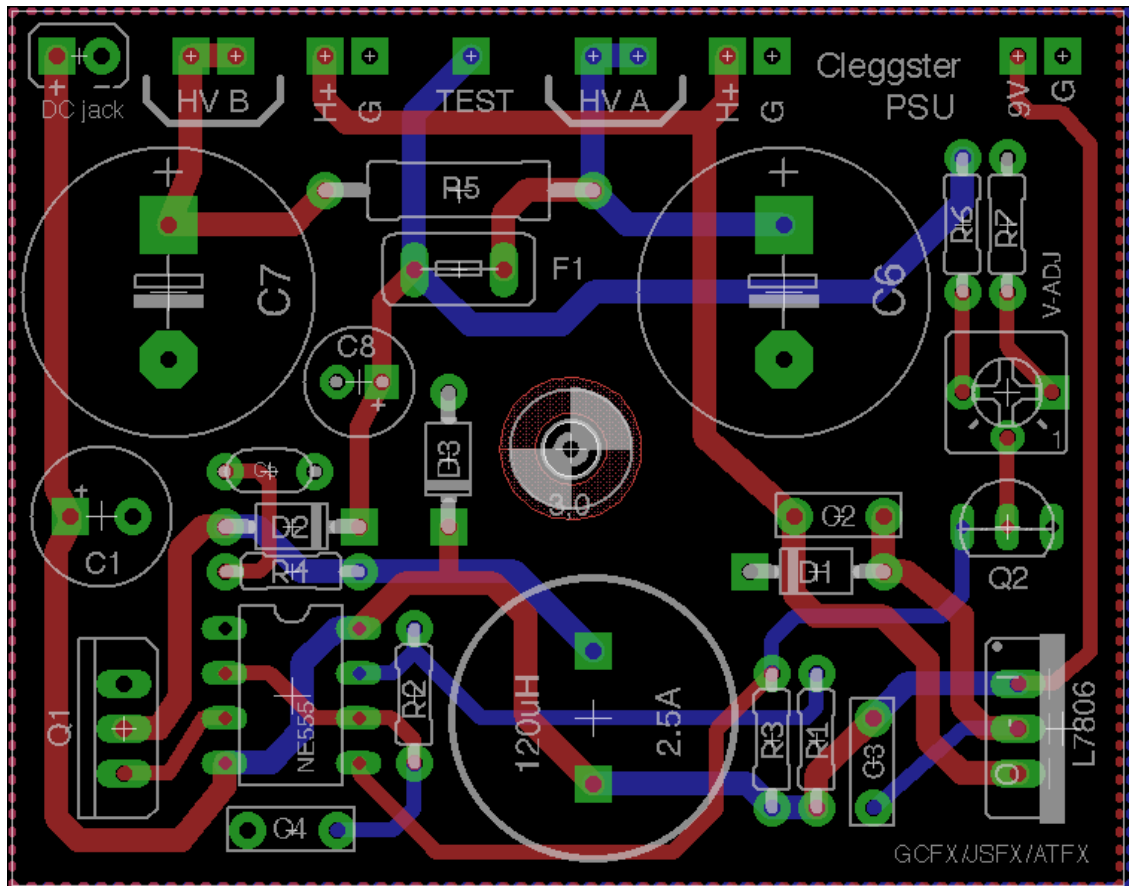

R1	1K	C1	330UF	D1	1N5817
R2	10K	C2	100NF	D2	UF4004
R3	56K	C3	330NF	D3	1N4001
R4	2K2	C4	2,2NF	Q1	IRF740
R5	10K	C5	100PF	Q2	BC547
R6	220K	C6	47UF	IC1	L7806
R7	470R	C7	47UF	IC2	NE555
		C8	2.2UF	F1	POLYFUSE
				IND	ELC16B121L OR 09HCP-121M-50 120UH

## BEFORE YOU START

Please read all these instructions and the important notes at the end.

# GRIND CUSTOMS FX

[WWW.GRINDCUSTOMSFX.COM](http://WWW.GRINDCUSTOMSFX.COM)

## ASSEMBLY

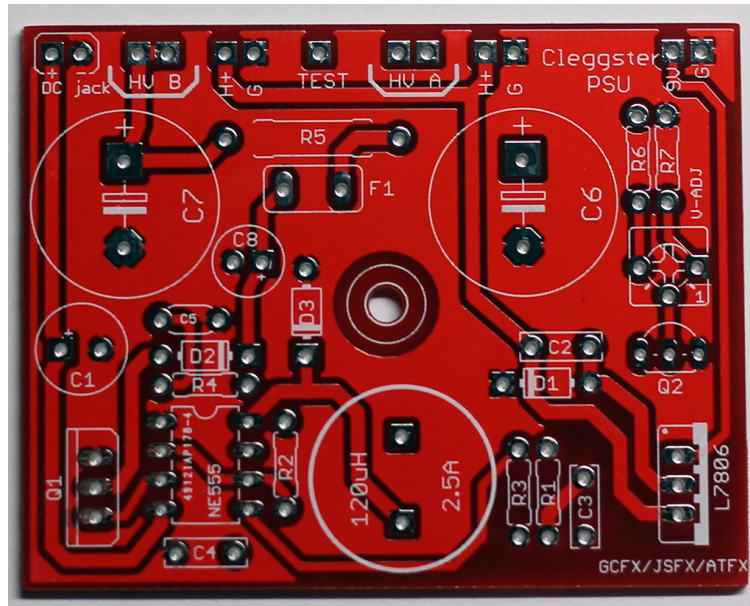

Grab yer board!

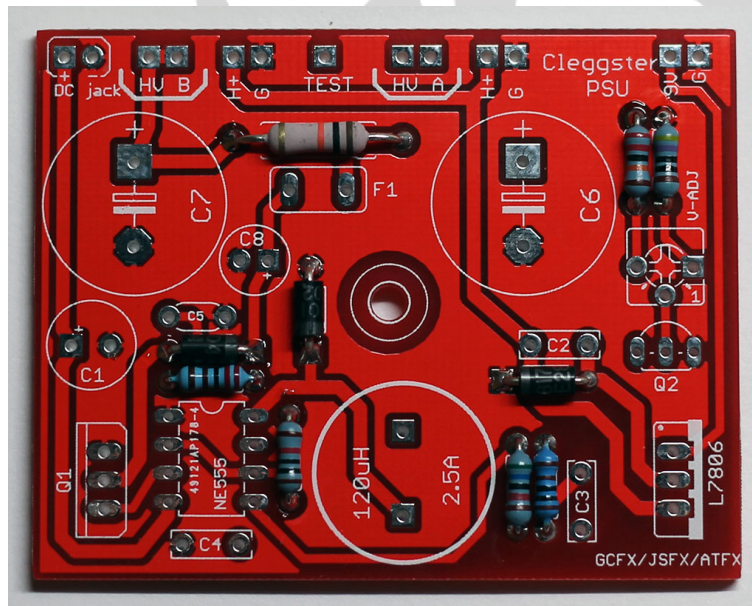

Start populating with the smallest components first. This is good practice anyhow. So in this case,  $\frac{1}{4}$  watt resistors, then diodes, then 1 watt resistor (R5)

# GRIND CUSTOMS FX

[WWW.GRINDCUSTOMSFX.COM](http://WWW.GRINDCUSTOMSFX.COM)

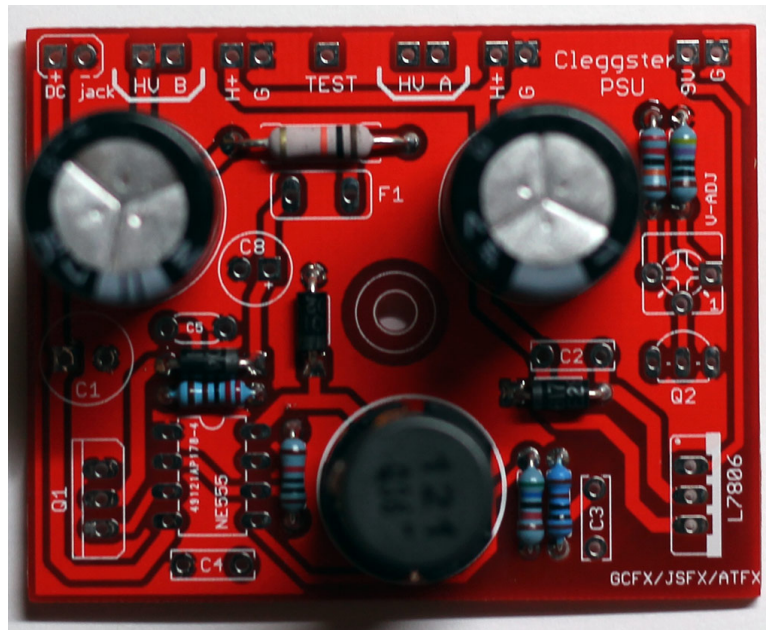

At least that's how I would have done it had Rej not bunged the big caps and inductor in next. ☺ However his argument is strong, as it involves gravity, which stops us all floating around. Putting the big components in first allows the smaller components to dangle so when you solder them in, they are straight. This use of Newtonian thinking is acceptable to my OCD.

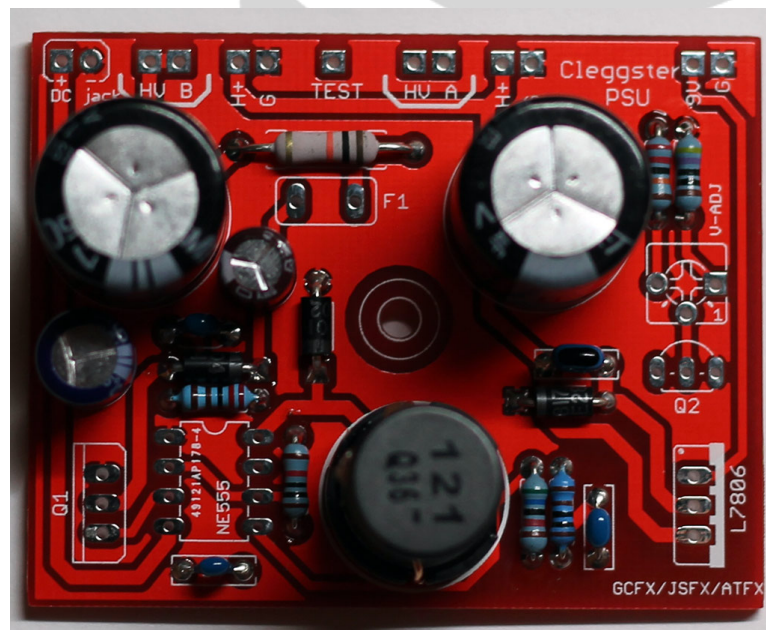

Next for me would have been the IC, then the trimmer, then the MLCC caps, then the polyfuse and then the shorter electrolytics. You get the idea.

The polyfuse by the way, is a self resetting fuse. How cool is that!?

# GRIND CUSTOMS FX

[WWW.GRINDCUSTOMSFX.COM](http://WWW.GRINDCUSTOMSFX.COM)

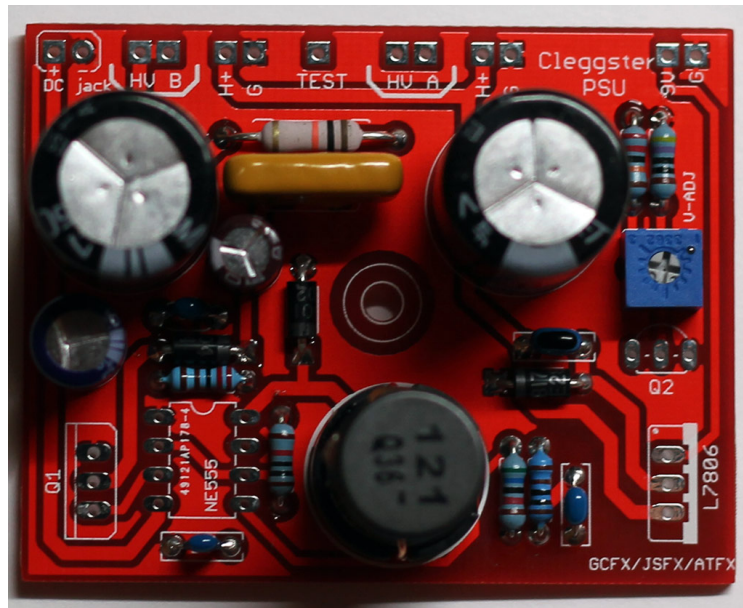

Still this doesn't explain the IC and trimmer. They don't dangle. I feel his logic has some merit, but also some flaws regarding the dangle factor of certain components.

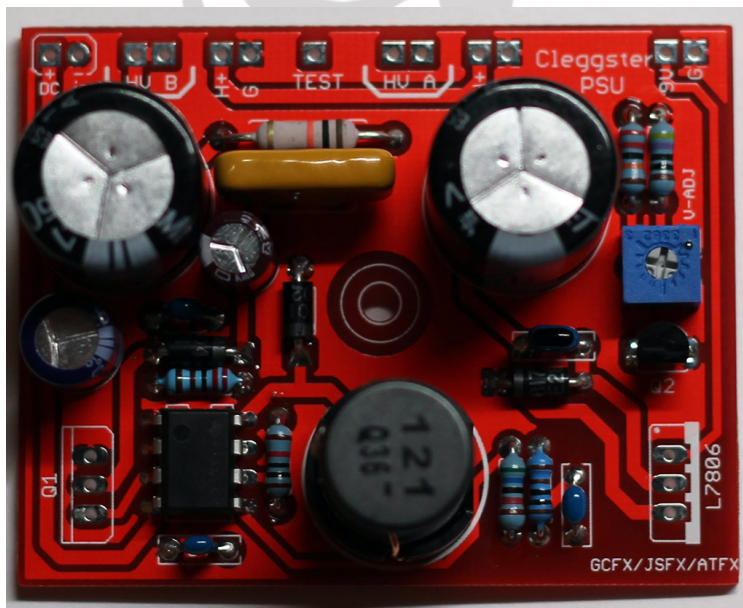

Aha! Back on track, and this bit I absolutely agree with: fit everything apart from the mosfet and regulator, he has a nice trick for those.

# GRIND CUSTOMS FX

[WWW.GRINDCUSTOMSFX.COM](http://WWW.GRINDCUSTOMSFX.COM)

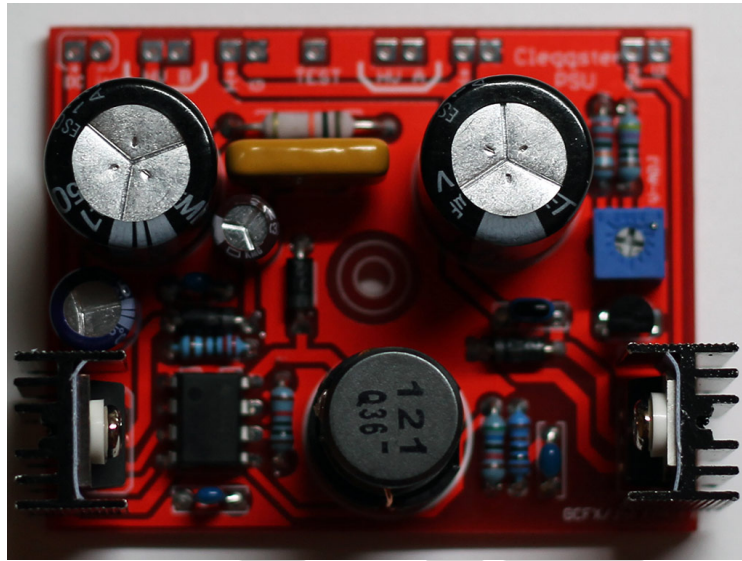

The trick is to fit the heatsinks (as per appendix A over the next page), place the assembled fet and reg in the board, then turn it over so it sits on the caps and inductor. This nicely sets the height of the two before you solder them in. Simple, yet clever at the same time.

## TESTING

Once you are confident that everything is right, stick the 9v and GND leads in, hook it up and grab your multimeter. Stick it on DC and probe a ground pad and the test pad. Turn the trimmer until you get 190V.

Then do a quick sanity check. The HV pads should read 190V and the heater pads around 6V to 6.3V. Now unplug it and keep an eye on the HV until it's discharged before you start poking around with it again. Without any load on the supply it'll probably take a couple of minutes. Until it's discharged, even unplugged it can still get you. Treat it like an amp.

## DISCLAIMER

This is a high voltage DIY PSU. As such, if you're not confident dealing with this sort of thing, don't! As stated earlier, it can give you a nasty shock and will have enough poke in it to potentially kill you if manage to fire that across your heart.

If you die, please do not haunt us. We warned you over and over.

# GRIND CUSTOMS FX

[WWW.GRINDCUSTOMSFX.COM](http://WWW.GRINDCUSTOMSFX.COM)

## APPENDIX A ASSEMBLING HEAT SINKS

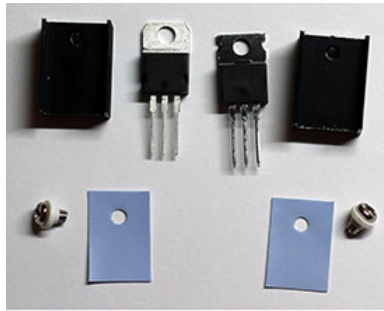

STEP 1

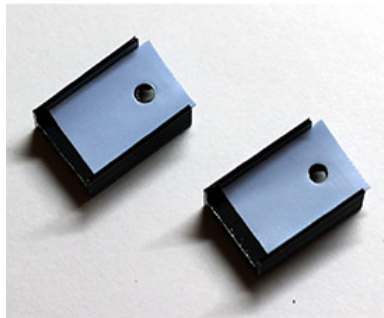

STEP 2

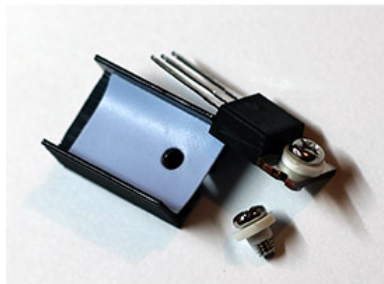

STEP 3

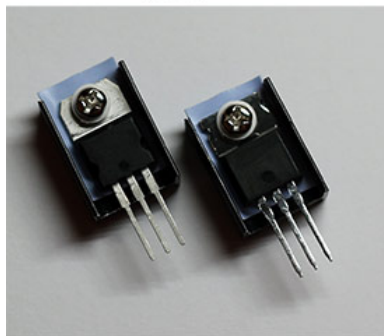

STEP 4

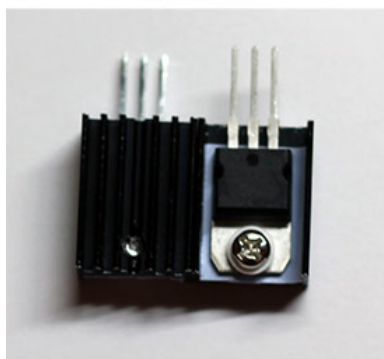

STEP 5

1. Grab the parts, these are:  
1x L7806 Regulator  
1x IRF740 Mosfet  
2x Heat transfer pads  
2x Heat Sinks  
2x Bolts with washers
2. Put the heat transfer pads into the heat sinks.
3. Put the bolt through the washer then through the component
4. Bolt the component to the heat sink
5. Trim off the excess heat transfer pad

# GRIND CUSTOMS FX

[WWW.GRINDCUSTOMSFX.COM](http://WWW.GRINDCUSTOMSFX.COM)

## APPENDIX B IMPORTANT NOTES

1. It is designed to run from a 9v supply and 9v supply only. Running it from a higher voltage source will cause the regulator to have to do more work and dissipate even more heat in the process. It already gets hot enough.
2. As mentioned, running 2x 12AX7 valves, the regulator will run at around 130 degrees C. Which the heat sink can deal with no problems. However it can be beneficial to bolt the regulator (L7806) to the case (providing it's aluminium) as this will make an even better heat sink and lower the in case temps a bit. Still use the thermal pad though, as it helps transfer the heat better.
3. The Mosfet (IRF740) MUST NOT be bolted to the case however. The outside of the fet is live, bolting it to the case would be a bad thing. If you're unsure of the definition of 'a bad thing' I refer you to the movie Ghostbusters. It runs at around 80 degrees C anyhow, so really doesn't get that hot.
4. Do not go over 190V. The supply will become unstable beyond this. Plus 190V is plenty to make most valves work properly.
5. 190V is easy to set with no load. Once you build your effect you might find that the voltage under load is less. Personally I don't adjust this, but Rej re-adjusts it to 190V by once again probing the test point. As long as the supply remains stable this should be fine. He hasn't blown up yet.
6. Don't use sockets for the IC, or anything else for that matter. Solder everything.

## APPENDIX C PART IDENTIFICATION

R1: 1K 1/4W Brown-Black-Black-Brown-Brown  
R2: 10K 1/4W Brown-Black-Black-Red-Brown  
R3: 56K 1/4W Brown-Red-Black-Blue-Green  
R4: 2K2 1/4W Brown-Brown-Black-Red-Red  
R5: 10K 1W Metal Oxide Gold-Tan-Orange-Black-Brown  
R6: 220K 1/4W Brown-Orange-Black-Red-Red  
R7: 470R 1/4W Brown-Black-Black-Purple-Yellow

C1: 330uF 25V  
C2: 100nF MLCC 104  
C3: 330nF MLCC 334  
C4: 2n2 MLCC 222  
C5: 100pF MLCC 101  
C6-C7: 47uF 250V C8: 2u2 250V

F1: Polyfuse

Trimpot: 2K



# GRIND CUSTOMS FX

[WWW.GRINDCUSTOMSFX.COM](http://WWW.GRINDCUSTOMSFX.COM)

## APPENDIX D SCHEMATIC

